

HORIZONTAL WRAPPING MACHINE TE 400 B



THE ALL-PURPOSE BASIC MACHINE



FIXING. WRAPPING. PACKAGING.

MACHINE PARAMETERS

The **TE 400 B** is constructed according to our well-designed system that has been proven on the market. It is a manually operated wrapping machine that can be used universally. The work table can be adjusted to fit the task, respective of intended use and product. The position of the wrapping head can be mounted at three different heights

according to the application. Our special machine design allows for operation directly in the wrapping area without any danger. This ensures that the handling and the wrapping process can be simply and safely performed even on smaller and shorter products. Also, the wrapping ring rotational speed, which is adjustable via a potentiometer, further expands the range of application for this modern and reliable wrapping machine.

USE

The products are placed on the working surface of the machine and pushed as far as the wrapping ring. The operator grips the film and starts the drive of the wrapping reel by using the foot-actuated switch. After the second revolution, the film is fixed and the bundling or wrapping process can be continued. If the foot-actuated switch is no

longer actuated, the wrapping ring stops in the position in which the film can be freely gripped and cut. The film tail is pressed to the product by hand.

TECHNICAL DATA

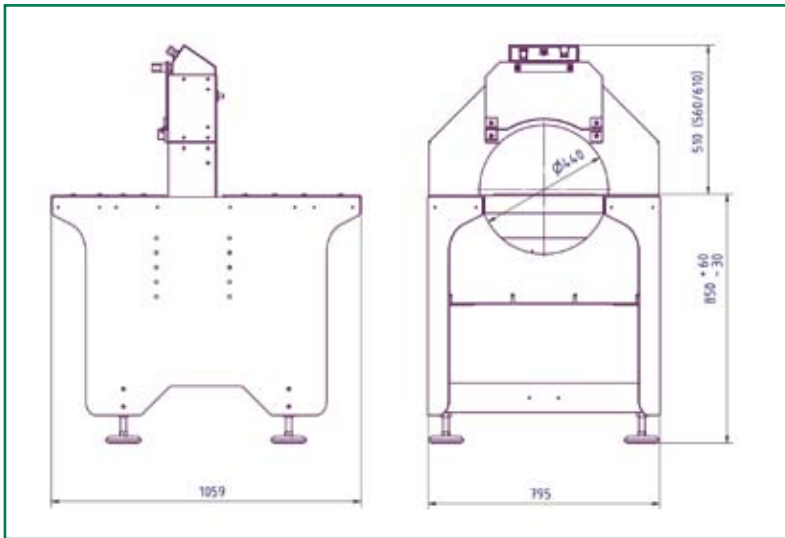

The wrapping head can be mounted at three heights.

- Product cross section maximum = 400 mm
- Variable wrapping ring rotational speed from 32 to 180 1/min (0.5 to 3.0 1/sec)
- Film width maximum 80 mm
- Film roll external \varnothing maximum 120 mm
- Roll core \varnothing = 38 mm
- Machine mass = 166 kg
- Electrical connection 230 V / grounded socket / 0.55 kW



ADVANTAGES THAT SPEAK FOR THEMSELVES

Always the latest state-of-the-art technology

- Outstanding machine flexibility
- High wrapping ring speed
- Maximum efficiency
- Processing rates
- Well-engineered machine technology
- Simple operation
- Silent running

- Exclusive use of brand name components
- Minimal downtimes
- Maximum operator safety
- CE Marking
- Quick spare parts supply
- Reliable service

Fahrenkaemper Entwicklungs- und Vertriebsgesellschaft mbH

Kampstrasse 35
32584 Loehne | Germany
Phone +49 (5731) 86 001-0
Fax +49 (5731) 86 001-11

info@fev-gmbh.de
www.fev-gmbh.de